

Demo or Class: The Ellsworth Signature Gouge



by Carl Ford (7/16/2009)

Turning green logs with the David Ellsworth Signature Gouge is fun and easy. This weekend workshop open to **beginners and intermediate turners** will focus on turning medium size (8 to 12") bowls from green (wet) logs.

Topics will include

- Wood selection
- Cutting the raw log
- Mounting the blank
- The David Ellsworth Signature Gouge (cuts and sharpening)
- Jam chucking and vacuum chucking

Instructor

Carl Ford

To Schedule a Demo or Class:

Send email to carl@carlford.info with date, time, and type of group.



Eraser

Chalk

Class: The Ellsworth Signature Gouge Handouts:

by Carl Ford (7/16/2009)

Books

Ellsworth on Woodturning, How a Master Creates Bowls, Pots, and Vessels, by David Ellsworth. A great must have book!

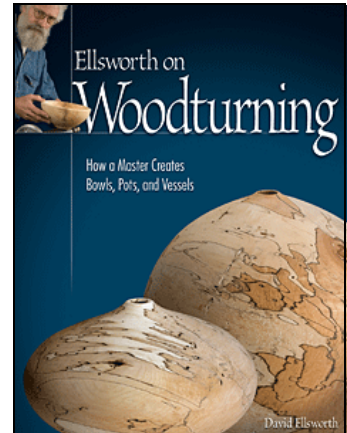

DVDs

1. **The Ellsworth Signature Gouge**, by David Ellsworth. One of the best woodturning DVDs. Camera is over David's shoulder so you see what David sees. You see what angle David is holding the gouge at, etc.
2. **From the Tree to the Table**, by Mike Mahoney

Turning Tools:

1. **The Ellsworth Signature Gouge**, Just plain old M2 high speed steel (HSS). No fancy Pro-PM, etc, steel. Extra hard steel takes too long to sharpen properly.
The Ellsworth gouge manufactured by "Henry Taylor" comes sharpened with wrong shape. The one manufactured by "Crown Tools" is very close to correct.
2. **Bottom Ellsworth Signature Gouge**, (Optional) Same as above sharpened with 1 3/8" tip (rather than 2") exposed in Ellsworth Sharpening Jig. Steeper angle on end of gouge allows you to keep the bevel rubbing across bottom of bowl.
3. **Bowl Gouge for Roughing**, (Optional) "P&N" 5/8 inch (16mm) Bowl Gouge, sharpened like a Ellsworth with **no wing**. i.e. straight swept back grind (Irish grind). See John Jordan segment on AAW Sharpening DVD. 5/8" is available from www.packardwoodworks.com
Use for roughing out. Save the more expensive Ellsworth gouge for finish work. No wing makes the tool less aggressive during rough out.
Use in dry wood. Wings on Ellsworth Grind make it too aggressive in dry wood.
4. **Detail Gouge**, "P&N" 1/2 inch (12mm) Detail Gouge with Michael Hosaluk Grind.
Used to finish outside bottom of bowl. For cutting off the nib when jam or vacuum chucking.
5. **Heavy Duty Parting Tool**, (Optional) "Ellsworth Small Straight Hollowing Tool".
Used to part bowl almost off of face plate before finishing the bottom with detail gouge.
You can just push this tool straight into work. You do not have to ride the bevel. Handles a mixture of side and end grain with ease
Or "Straight Blade from McNaughton **Micro** Center Saver". This is a bowl coring tool! Do not confuse it with Hollowing Tools also made by McNaughton. (www.woodturnerscatalog.com item # 095-4015). When I purchased one of these it came poorly sharpened. To get it to cut straight, I had to sharpen it so angles on the point were identical.



6. **Handles**, (For Thompson or Ellsworth **Small** Hollowing Tools) “17 Inch Ash Wood Handle” from www.woodturnerscatalog.com. Same as handle on Ellsworth Signature Gouge. Or “Hosaluk 18 inch Aluminum Handle”. Steel handles, especially the Oneway handles are too heavy!

Sharpening:

1. **Ellsworth Grinding Jig**, Or Wolverine Vari-grind Jig. The Ellsworth jig is fool proof.
2. **Grinding Wheel**, 8” x 1” x 1”, Gemini, 120 Fine Grit, Aluminum Oxide by Norton. www.mscdirect.com item #75941443



Faceplates:

1. **#14 Stainless Steel Sheet Metal Screws**, I prefer square drive. www.mcmaster.com item #93945A071 for 1.5 inch long screws. Must be Sheet Metal screws. No drywall screws! No wood screws!
2. **UHMW Plastic Sheet**, Attach to faceplates and counter sink screw holes and center area. 1/2” thick by 12” x 12” www.mcmaster.com item #8769K71
3. **Impact Driver** (Electric Screwdriver). “Makita 12V Cordless Impact Drive Model: 6980FDWDE” or similar.



4. **Oneway 4” & 6” Versa Mount Rings**, (highly recommended) Allows you to mount heavy blocks of wood with ease! Purchase direct from www.oneway.ca
5. **Oneway Versa Mount Coupling Hub**, To go with the above. You just need 1 that matches the threads on your lathe.
6. **Alternatives to Oneway Versa Mount** (more expensive in the long run)
 - 6a. **Oneway 4” Steel Faceplate**, Steel is best. Thin cast iron is no good. Will crack. Aluminum is too soft for lots of use.
 - 6b. **Oneway 6” Heavy Duty Cast Iron Faceplate**, real thick cast iron is ok.
 - 6c. **6” Custom Faceplate**, order an Ellsworth Style faceplate with 1/4” holes, counter sunk front and back from Bill Kuhlemeier, 486 Banks Chapel Road, Ranger GA 30734, 706-334-4057



Tool Rests

1. **1” Shaft Collars**, or stick a piece of dowel down the tool rest hole. Keeps the tool rest at correct height. I like cheap 2 piece collars. www.mscdirect.com item #35461086
2. **Oneway Interior Bowl Rest**, heavy duty, gentle curve.
3. **Custom Interior Bowl Rest**, any size and shape you want. I like tight curve. See my drawing. Order from Bill Kuhlemeier, 486 Banks Chapel Road, Ranger GA 30734, 706-334-4057



Tailstock Centers

1. **Oneway Live Center**, a great center. I use this for most of my work.
2. **Revolving Center System**, with **Small Cup Accessory Point**, by Precision Machine. Available from www.woodturnerscatalog.com
Small point makes it easier to center things when jam or vacuum chucking. The point on Oneway center makes a big hole that makes it hard to move over just a tiny bit.



Sand Paper

I buy all of my sanding supplies from Vince's Wooden Wonders. <http://www.vincewoodnwonders.com> Vince is the only person who sells Siasoft Red Foam in USA.



1. **Siasoft Red Foam Backed Sandpaper**, really tough, does not tear easily like 3M stuff! 80, 120, 150, 180, 220 grit. **Get the red stuff. Not the blue stuff.**

Good for wet sanding or dry sanding. Wash it off in a bucket or under facet if it jams up while sanding green wood.

Great Deal! \$7 per yard. Similar to the 3M purple stuff sold by Lowe's for \$8 per small pack.

2. **Siasoft Blue Sanding Disks**, 2 3/8" disks are \$11 for 50. 3 3/8" disks are \$12 for 50. I use 80, 120, 180, 220, 320 grits.

The velcro on these disks is glued onto a very tough sandpaper. They work wet or dry.

Heat will build up and soften the glue if you sand aggressively with these disks. When you try to remove the disk the velcro will get screwed up. To avoid this problem you need **Interface Pads!**

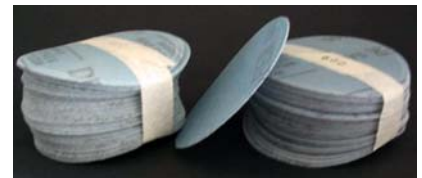

3. **Interface Pads**, 2 3/8" & 3 3/8" to match disks. I use Firm Interface Pads for 80, 120, 180 grits. Soft Blue 3/8" Foam Interface Pads for 180, 220, 230. Most of my firm pads are tapered edge. I use radius edge pads to get into corners. The sandpaper wraps up around the edge of radius edge pads.

1 interface pad for each grit works best! Allows quick and easy grit change without screwing up the velcro.

4. **Thick Back Up Pads**, 2" & 3". The thing that you chuck up in the drill. 2" pad goes with 2 3/8" disks and interface pads. 3" goes with 3 3/8"

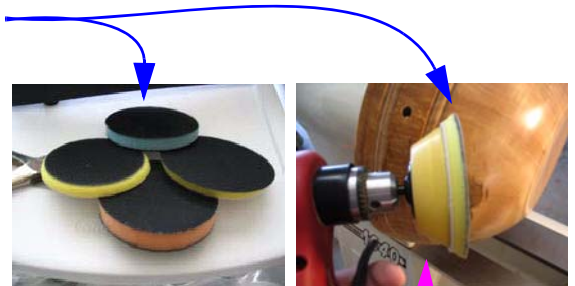

Chain Saw

1. **Husqvarna (Husky)**, Model# 359, 20 in. Bar, 3.9 HP, .325" / 3/8" chain pitch. The 359 has decompression button on spark plug for easy starting.

Husky are better than Stihl at rip cuts. They clear the long stringy chips better. Bigger saws with .325" / 3/8" chain pitch are better at rip cuts. The Husky 460 Rancher is another good choice.

2. **Husqvarna Sharp Force File Guide**, makes sharpening chain saw easy and fast. See <http://www.forestapps.com/pferd/pferdtool.htm>



Eraser

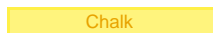

Chalk

Carl Ford's Bowl Turning Process (Cut Edge and Natural Edge)

This process skips the "mount the bowl blank between centers" so you can align the grain step that some people advocate. Careful chain saw work avoids the need for this.

Mounting a blank between centers can be problematic even on heavy duty lathes. Skipping this step avoids a lot of mental stress and danger. It saves time. Not aligning the grain perfectly often creates more pleasing natural edge bowls



1. Prepare the bowl blank.

- 1a. Start with a green log about 6" longer than it is round.

In an ideal world the extra 6" allows you to cut 3" off both ends to eliminate any cracks. In the real world you may have to make due with less than 6".

- 1b. Rip the log in half with a chain saw. Cut through the pith. Draw some lines and think about the grain before you start cutting!

Careful work at this stage avoids the need for mounting the blank between centers to align the grain.

- 1c. Goto next step with one half of the log. Save the other half for your next bowl.
- 1d. Use a plywood circle template to knock the corners off of blank with chain saw.

2. Mount the bowl blank.

- 2a. Mount faceplate in the middle of blank on the rip cut side. Use good stainless steel sheet metal screws.
- 2b. Screw the faceplate onto the lathe. Bring up the tailstock for safety.
- 2c. **Put on your faceshield!** Hand rotate the bowl blank. Make sure it spins free!
- 2d. Set the speed to as slow as possible! **Stand to the side.** Turn on lathe.



3. Rough out the bowl blank. (Skip this step for Natural Edge Bowls)

- 3a. Use Ellsworth gouge with roughing cut to make it round. It does not need to be perfect at this stage.
- 3b. Use Ellsworth gouge with roughing and/or scraping cut to create a place to mount faceplate on the bark (tailstock) side.
- 3c. Remove the blank from lathe.
- 3d. Remove the faceplate.
- 3e. Mount the faceplate on bark side.
- 3f. Screw the faceplate back onto the lathe.



4. Turn the outside of bowl.

- 4a. Use Ellsworth gouge with roughing cut to make it round.
- 4b. Use Ellsworth gouge with push cut to create final rim height of bowl. It should be 1" below pith to avoid cracks in rim. (Skip this step for Natural Edge Bowls)
- 4c. Use Ellsworth gouge to create outside shape of bowl. Use the roughing, slicing and/or push cut.

Chalk

The push cut is technically going the wrong way, up hill, but it often works best on really green wood. Remember to make the outside bottom of the bowl about 1" above the faceplate to avoid the screws in faceplate and leave room for parting off.

If Natural Edge bowl then remember you need to cut towards the faceplate over the natural edge section of the bowl to avoid ripping the bark off.

If Natural Edge then super glue the bark onto the bowl. You need to saturate the cambium layer just below the bark and the bark with thin super glue. Do not get glue on main part of bowl, it will spoil the finish. **Beware of the super glue fumes! Stand back when you apply the accelerator.** Do this now so shear scraping done in next step will clean up any glue mess.

4d. Use Ellsworth gouge with shear scraping cut to finish outside of bowl.

5. Turn the inside of the bowl.

5a. Use Ellsworth gouge with interior roughing cut.

Remember the bevel must be rubbing at all times inside of a bowl! No shear scrapping!

5b. Use Ellsworth gouge with interior finish cut.

Remember that flutes at 90 degrees to tool rest is the safest, but does not cut well. At 45 degrees you get a good cut. At 0 degrees you will get a huge catch!

5c. **If Natural Edge** then super glue the bark onto the bowl again from the inside.

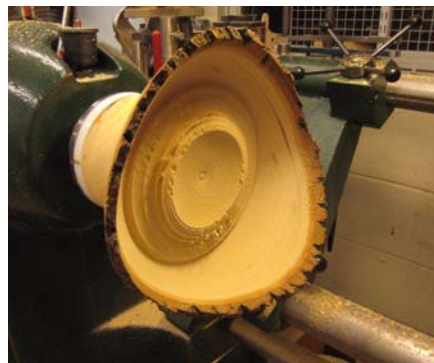

6. Finish the outside bottom of the bowl.

6a. You can't dry sand green wood. But, if you want to try anyway now is the time. Wet sanding works great!

6b. Use a parting tool or small Ellsworth style hollowing bar to create a parting cut just above the screws in faceplate. Leave about 1" tenon.

6c. Stop the lathe and cut the tenon with a hand saw. A tree pruning saw works good on green wood. You may want to wait and do this after next step!

6d. Reverse the bowl onto a jam or vacuum chuck. Use a live center in tailstock with a small point.

6e. Use Ellsworth gouge to remove most of the waste and finish bottom. Leave just a 1/2" diameter nib around live center holding the bowl. Scraping cut to remove waste. Push and shear cut to finish up.

6f. Use Detail Gouge with Michael Hosaluk grind to remove nib and part off to finish the bottom.

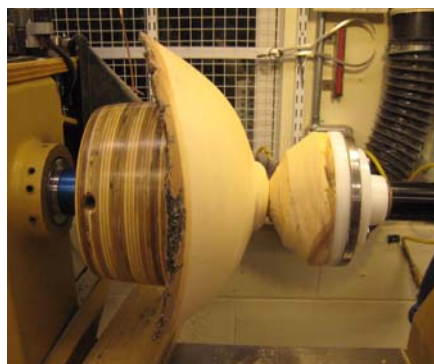

7. Finish the bowl.

7a. Soak the bowl 24 hours or longer in Denatured Alcohol to kill any mold, fungus, etc. Also speeds up drying. See "Carl Ford's Alcohol Drying Method".

7b. Sand dry bowl.

A 2" and/or 3" sanding disk mounted in a drill press is often the easiest method. Hold the bowl in your hands and move it around under drill press sander.

7c. Apply your favorite finish. Watco Danish Oil is easy and fast.



Carl Ford's Alcohol Drying Method

I use this method to prevent mold and mildew problems while drying green turned bowls. The alcohol also speeds up the drying of the green bowls by replacing the water with alcohol.

1. Fill a 5 gallon plastic paint bucket with easy on/off lid with 4 gallons of Denatured Alcohol.

Purchase bucket, lid, alcohol from Home Depot, Lowe's etc.

You want the kind of lid that snaps on/off easily. Used by professional painters. Rather than the kind of lid that requires a screwdriver and hammer to remove.



2. Soak bowl in alcohol overnight or longer.

I often soak things for 3-4 days. I have soak things for 2 weeks. No ill effects.

3. Remove the bowl and allow it to air dry for a few hours.

4. Wrap the entire bowl in Red Rosin Paper (floor underlayment paper) and let the bowl air dry slowly for 1-2 weeks. Or a brown paper bag from food store.

Store the bowl in a **cool** place while waiting for it to dry.

Change the paper every day or so when it gets damp. You can reuse the paper just let it dry for a few days, then reuse.

Purchase Red Rosin Paper from Home Depot, Lowe's etc. Its cheap.

Note: Some people make hats for there bowls that cover the outside and leave the inside exposed. The idea is the inside will dry faster, pull the bowl inwards and thus avoiding cracks. I have found this is not necessary and to much trouble.



5. When dry, sand and apply finish.

Wood

- Store your green logs in a cool place. **Outside**. Like under a tree. Out of direct sun! Keeping them damp is good, so do not protect them from the rain.
- Anything cut more than 6 months ago is **no longer green!** 3 months if cut in the summer.
- **Beware!** Spalted woods are caused by a fungus. A fungus that likes warm damp places. Like your lungs! Take proper precautions before turning spalted wood!
- Good woods for turning green. Native US hard woods are best.
 - Ash - Lots of light colored sap wood, nice brown heartwood. Few mold and mildew drying problems.
 - Walnut - Great white sap wood with dark heartwood. Hard to sand when dry. Allergy problems.
 - Cherry - Good color. Do not wet sand. Lots of mold and mildew drying problems.
 - Poplar - Soft. Cuts easy. Good for practice.
 - Boxelder - Attractive red streaks inside.
 - Apple - Often has big problems with cracking but the wood is pretty.
 - Maple - Hard to sand when dry. Often has unattractive streaks inside.
- **NOT** good for turning green. Avoid:
 - Pine - Or any other soft wood. To soft. To much sap in pine.
 - Oak - Warps to much in very unpredictable and unattractive ways. Hard to sand when dry.
 - Hickory - To stringy. Not fun to turn.
 - Red Cedar - To soft. Cracks easily. But, the great color may be worth the pain. Allergy problems.
 - Basswood - To soft.
 - Exotic Woods (Bubinga, Cocobolo, etc) - To hard. Can not get green. **Toxic dust problems!**
 - Anything that has been Kiln Dried. It's no longer green!

BEWARE! Your printer may not print this page correctly. Double check the 7 inch dimension and make any necessary adjustments. Change "Page Scaling" to "none" on Print Menu, etc.

Ellsworth Gouge with Ellsworth Jig & Arm

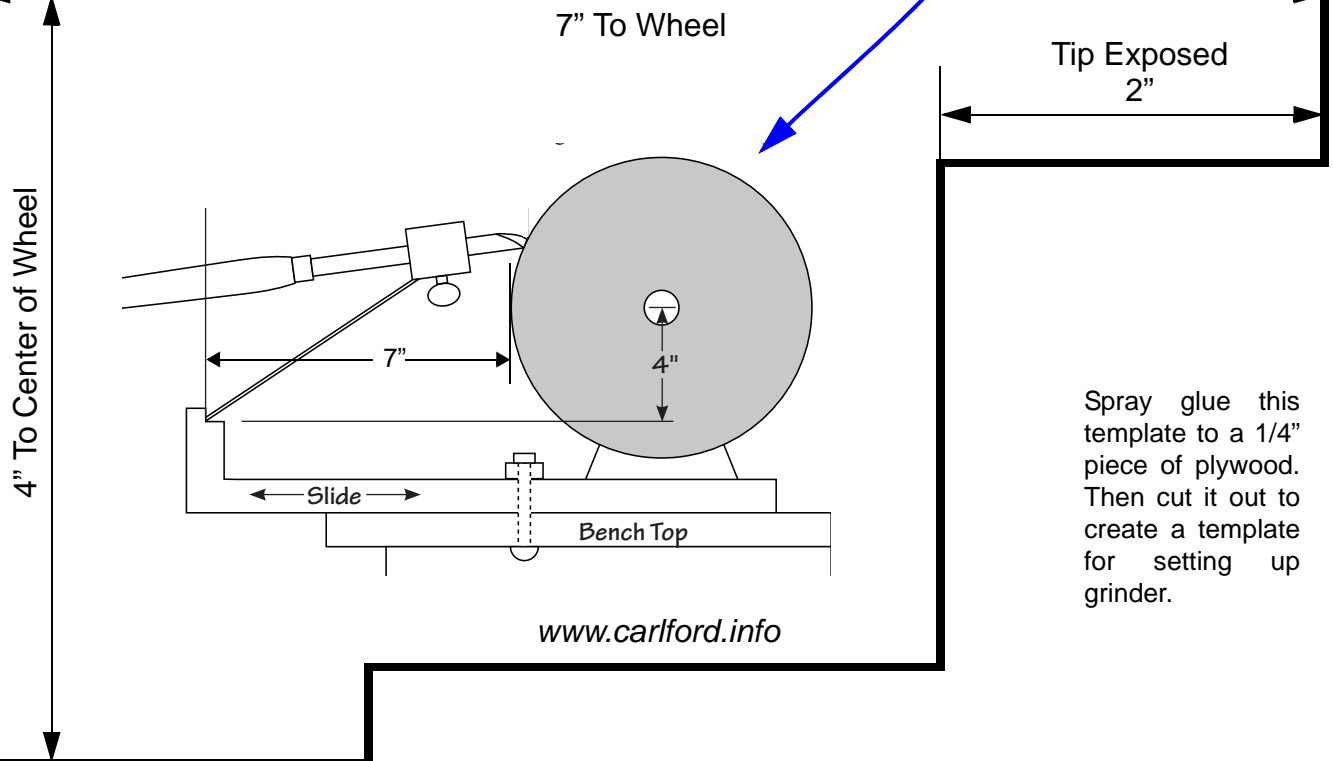
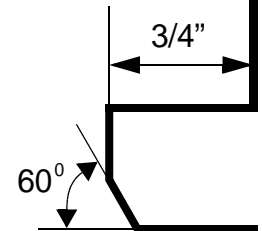
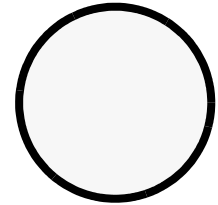
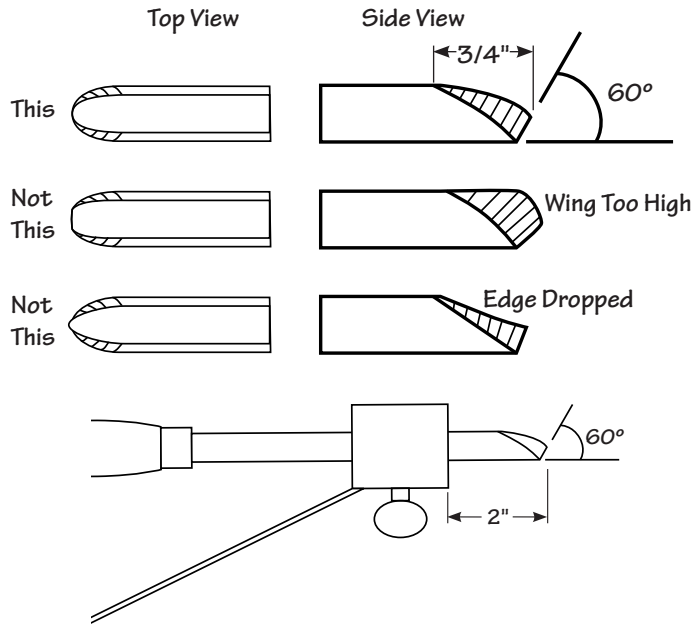

Spray glue this template to a 1/4" piece of plywood. Then cut it out to create a template for setting up grinder.

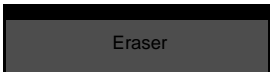

BEWARE! Your printer may not print this page correctly. Double check the 7 inch dimension and make any necessary adjustments. Change "Page Scaling" to "none" on Print Menu, etc.

Ellsworth Gouge with Ellsworth Jig, Wolverine Arm

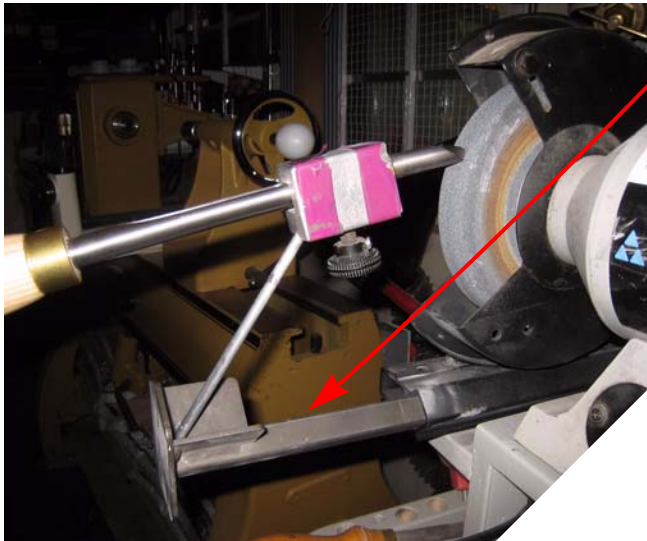
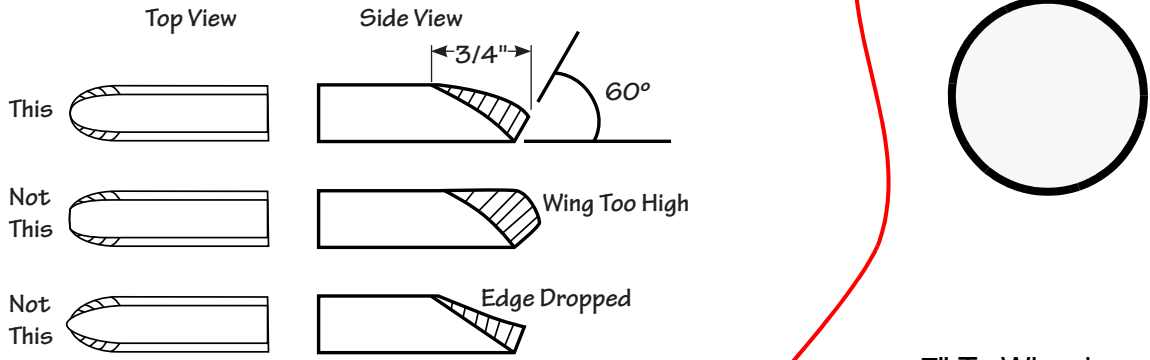

5 1/4" To Center of Wheel

Tip Exposed
2 1/8"

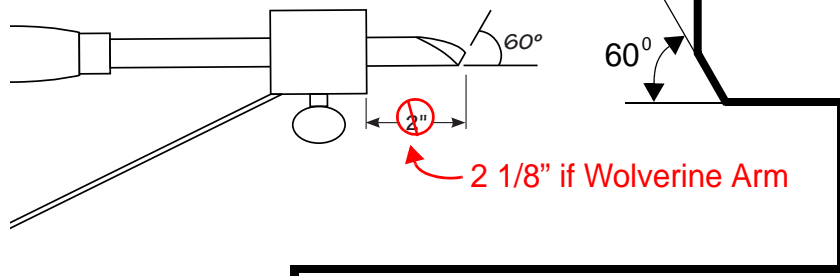

Spray glue this template to a 1/4" piece of plywood. Then cut it out to create a template for setting up grinder.

www.carlford.info

www.carlford.info

Chalk

Eraser

BEWARE! Your printer may not print this page correctly. Double check the 6 1/2 inch dimension and make any necessary adjustments. Change "Page Scaling" to "none" on Print Menu, etc.

Ellsworth Gouge with Wolverine Varigrind Jig

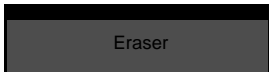
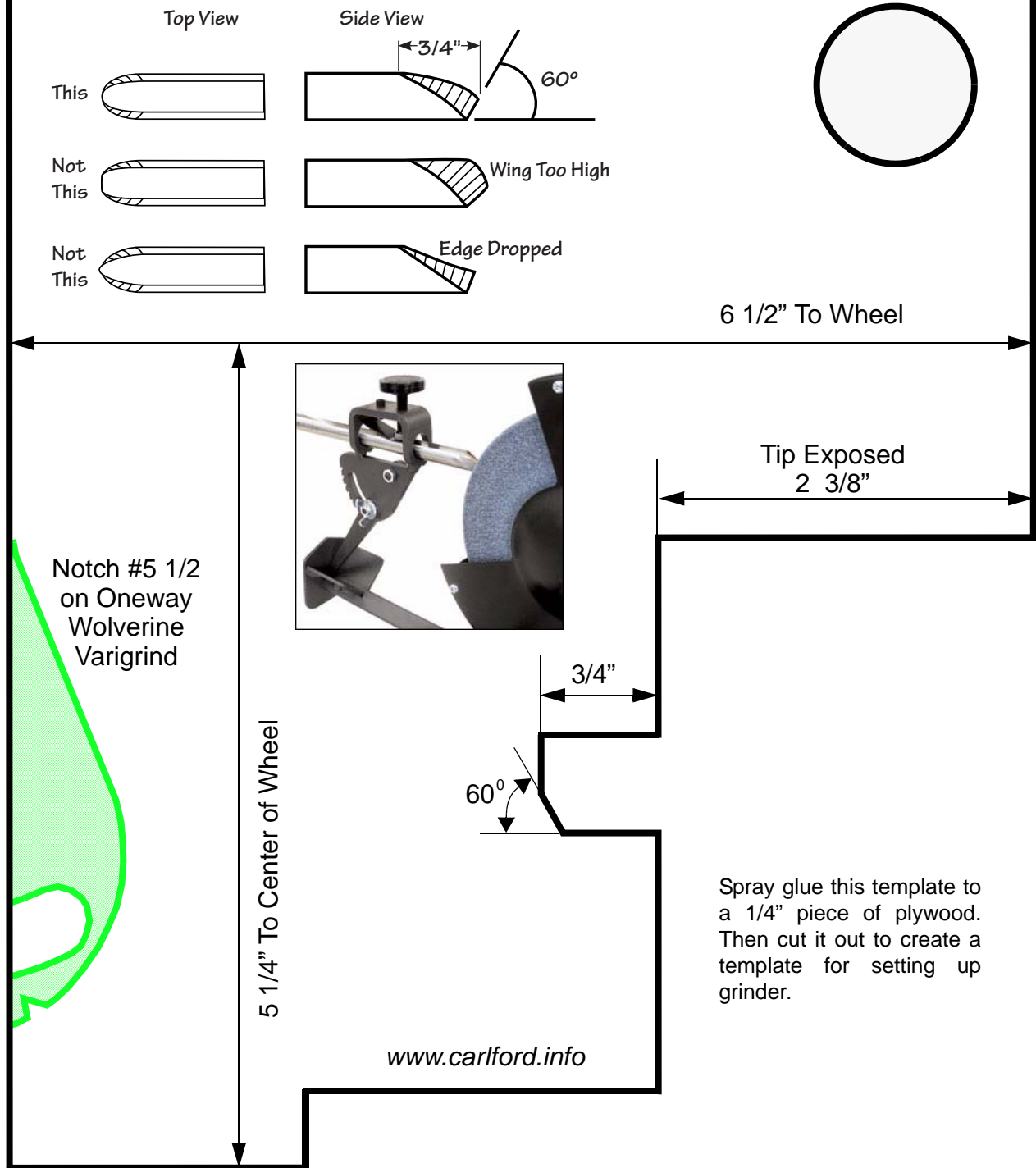

BEWARE! Your printer may not print this page correctly. Double check the 6 inch dimension and make any necessary adjustments. Change "Page Scaling" to "none" on Print Menu, etc.

12mm (1/2") Detail Gouge with Hosaluk Grind

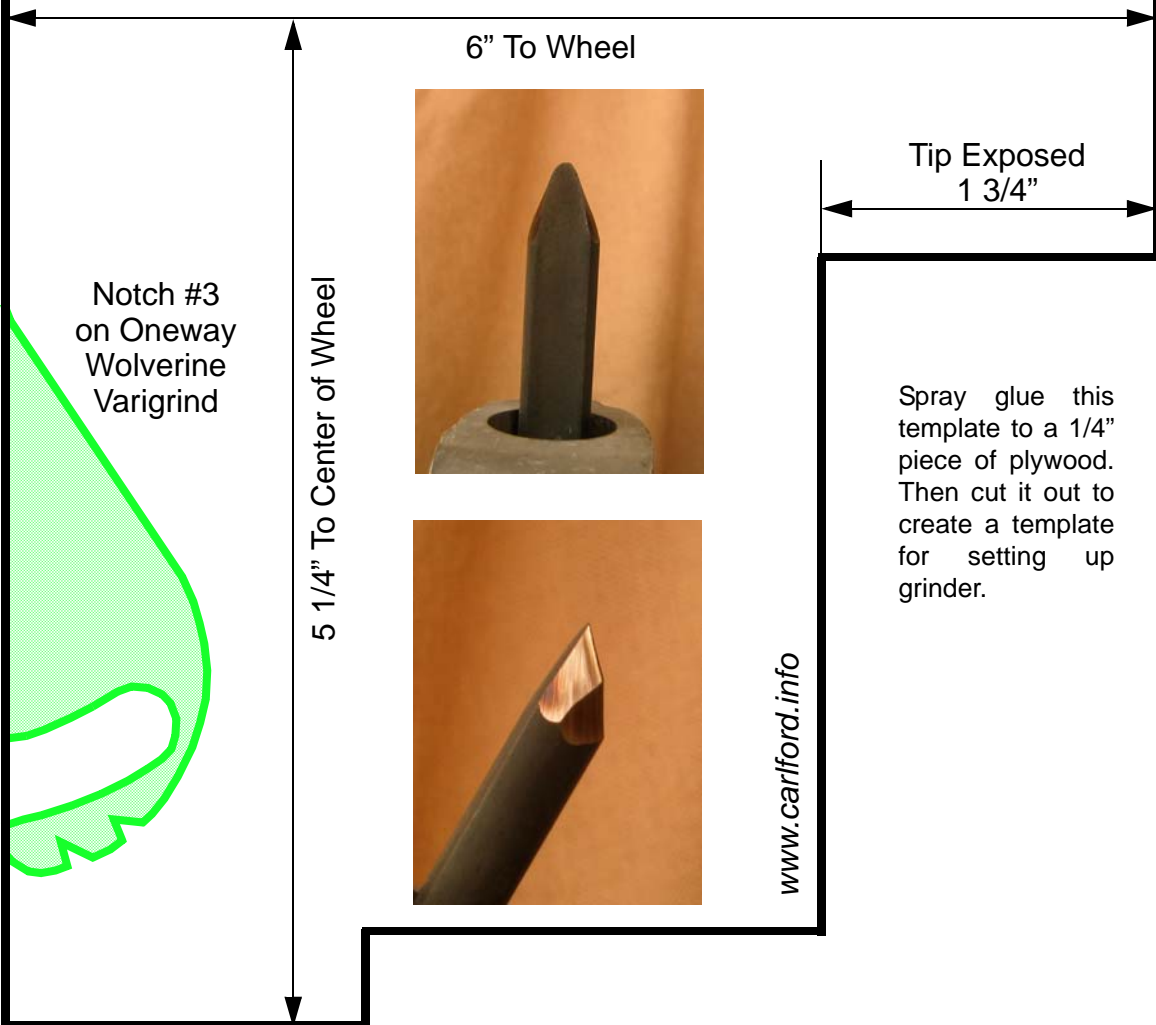
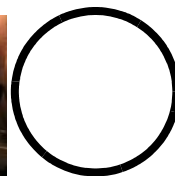

www.carlford.info

www.carlford.info

Eraser

Chalk