

Demo or Class: Small Vases & Hollow Forms



by Carl Ford (3/6/2009)

Turning small vases is a great low stress way to learn how to create hollow forms and to experiment with shapes and surface decorations.

Rattles and Christmas ornaments are another great use of small hollow forms that is fun to explore.

This demo focuses on turning and decorating a small hollow form vase from start to finish using Ellsworth style Small Hollowing Tools.

Topics will include:

- What makes a form easy or hard to hollow
- Wood selection
- Hollowing tools
- Procedure and tips for hollowing

Instructor

Carl Ford

To Schedule a Demo or Class:

Send email to carl@carlford.info with date, time, and type of group.



Chalk

Eraser

Demo Handouts:

Easy verses Hard Hollow Forms: (Rules of Thumb)





What makes a form easy to hollow?

- Not too deep. 4" or less for 3/8" Ellsworth style tools
- Only requires the straight tool. Or just a little bit of bent tool at the **top!**
- Big entry hole. 5/8" or bigger.

Soft wood. Turn green or use soft hardwoods like Popular or Ash.

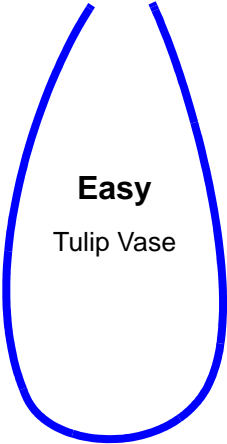
What makes a form hard to hollow?

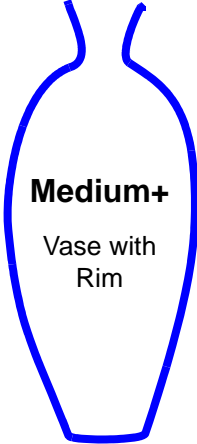
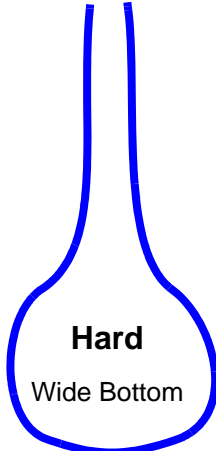
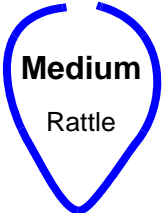
- Too deep. 6" is really pushing the limit for 3/8" Ellsworth style stools. 8" is limit for 1/2" Ellsworth style tools.
- Wide bottoms. Deep use of straight or bent tool to create wide bottom is hard. Use of bent tool is really difficult. Hard to handle torque. Hard to figure out where you are.
- Any use of the bent tool over 2" into a hollow form gets hard.
- Low wide vase forms are very difficult. Beyond capability of Ellsworth tools shown in this demo.
- Really hard exotic woods. Cocobola, African Blackwood, etc.

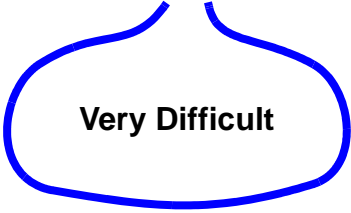
 <p>Easy Tulip Vase</p> <p>Straight tool only. Start Here with a Wide Opening!</p>	 <p>Medium Vase No Rim</p> <p>Straight tool and small amount of bent tool at top.</p>	 <p>Medium+ Vase with Rim</p> <p>Straight tool and small amount of bent tool at top. Not hard if rim flares out.</p>	 <p>Hard Wide Bottom</p> <p>Lots of bent tool deep inside of vase.</p>
 <p>Medium Rattle</p> <p>Straight tool and small amount of bent tool at top.</p>	 <p>Medium+ Xmas Ball</p> <p>Straight & bent tool. Not hard if small.</p>	 <p>Very Difficult</p> <p>May not be possible with straight and bent tools shown in this demo. Need to start making your own tools from Allen Wrenches, etc.</p>	

Eraser

Chalk

Hollowing Tools

Small Ellsworth Style Hollowing Tools

I **strongly recommend** purchasing a pair of small Ellsworth style Hollowing Tools rather than making your own. Over the last 25+ years David has refined the shape of his cutting tips so they really cut. Tools that don't cut or don't cut well due to poorly shaped tips are frustrating and dangerous.



David sells large and small tools. **You want the small tools. 3/8" by 6" shaft with 3/16" square cutter with 10% cobalt.** Good for hollow forms up to 4" deep. Available from Packard Woodworks at www.packardwoodworks.com for \$50 + shipping, item # 106209.

A pair of tools includes the "small straight tool" and "small bent tool". You really only need these two tools. David also sells a third "small high shoulder tool" that is best left to the pros. You only need it to do very difficult low and wide hollow forms.

If you want to make your own tools you can purchase 3/8" O1 drill rod and 3/16" square 10% cobalt tool bits from MSC Direct at www.mscdirect.com. MSC item number 06000244 (\$7) and 02605129 (\$3). Note: McMaster-Carr does not carry cheap imported tools bits.

Note: A 3 piece set of 5/16" Kelton Hollowing Tools for \$66 has recently become available thru Craft Supplies USA at www.woodturnerscatalog.com. 5/16" is 1/16" smaller than 3/8".



Medium Ellsworth Style Hollowing Tools

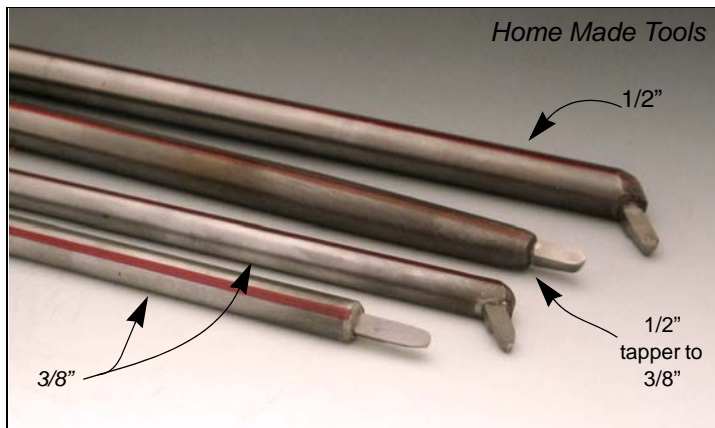

For hollow forms over 4" deep a set of tools made from 1/2" rods rather than 3/8" rods may be needed to reduce chatter. However, they may require a larger entry hole.

You can make your own tools by purchasing pre shaped 3/16" tool tips from Packard Woodworks at www.packardwoodworks.com item # 106215 (\$8) Also purchase 1/2" O1 drill rod from MSC Direct at www.mcdirect.com, item # 06000327 (\$10).

You may want to taper the end of 1/2" drill rods down to 3/8" to make them work better in tight spaces.

Note: A 2 piece set of 1/2" John Jordan Hollowing Tools for \$80 have recently become available thru Packard Woodworks at www.packardwoodworks.com. Kelton also has a 3 piece set of 1/2" tools for \$84 available thru Craft Supplies USA at www.woodturnerscatalog.com.



Eraser

Chalk

Don Derry Torque Arresting Tool Rest

I like the Don Derry "Lightning Hollower" system available from Don at www.derrytools.com because it features a torque arresting tool rest. However, the complete system price is a bit steep at \$319. The system includes a laser and straight boring bar in addition to the **torque arresting tool rest**. I like my own laser system better because it can be used on any tool, not just tools with square shafts.

You can **purchase just the Torque Arresting Tool Rest** from Don for \$69 plus \$15 for custom tool post for your lathe. This option is not on Don's web site. So you have to order by phone or email Don at don@derrytools.com (Prices as of 2/3/2008).

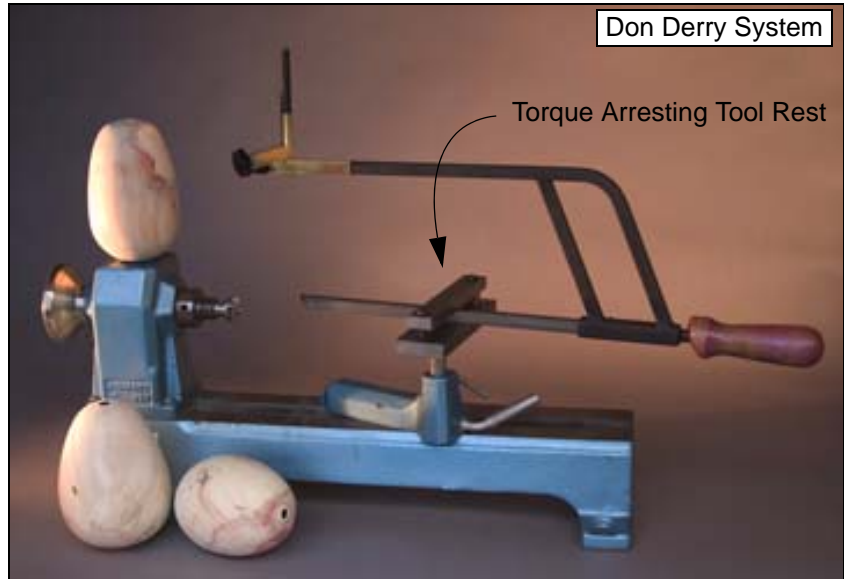

I personally do not like the Jamieson, Kelton, etc. style deep hollowing systems that use a secondary captured back rest. I never can find a comfortable place to put my hands. Can't unlock my knees and use the movement of my whole body to create nice smooth curves like I do when using a bowl gouge.

I really like Don Derry's system. I replace the short handle with a nice long handle and it feels like I am using a bowl gouge. It's like using Ellsworth's system except there are no torque problems!

The only disadvantage to the Derry system is you need to use square or octagon boring bars. Only available from Don Derry or make your own. See table below for make your own info.

The edges on your square boring bars should be rounded over with a belt sander! Otherwise they are big long scrapers that will wipe out the openings on your hollow forms!

Setup of Torque Arresting Tool Rest

I like to arrange the spacers between the top and bottom bars in my torque arresting tool rest so they are at a 45 degree angle with a 1" wide opening at the front and 2" at the back.

The narrow front opening helps me avoid whacking the openings on my hollow forms. I position the tool rest so I can use one of the spacers as a fulcrum point. This really helps in the bottom of deep hollow forms!

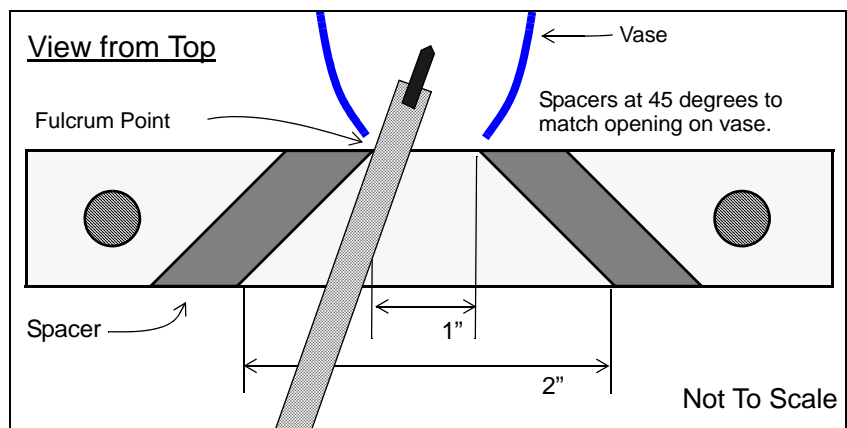

Chalk

Eraser

Books, Video Tapes and DVDs

Book: David Ellsworth just released a new book. "Ellsworth on Woodturning, How a Master Creates Bowls, Pots, and Vessels". The whole book is very good! It has two chapters on hollow forms with good photos of large and small tools and techniques. Available from David at www.ellsworthstudios.com, 247 pages, \$30

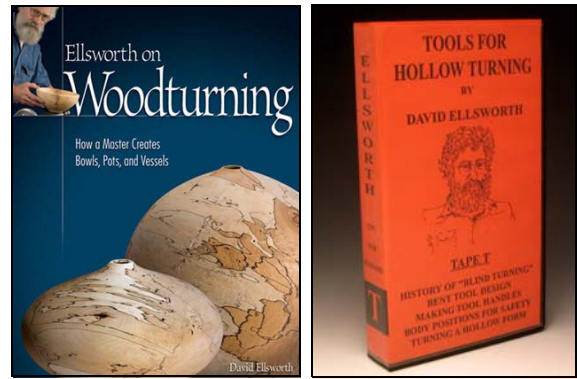

Tapes and DVDs: The following video tapes show how to use Ellsworth style hollow tools. The best way to learn is to watch it, then try it. Repeat until you master it.

- David Ellsworth "Tape T", available from David at www.ellsworthstudios.com, 60 min, \$30
Very good because it shows David hollowing thru a cut away hollow form. Also covers sharpening. This video shows David's large tools. The same advice and procedures apply to his small tools.
- John Jordan "Hollow Turning", No longer available? Borrow from your local Wood turning Club.
John shows his "steps" approach to finding his way around inside of a hollow form.

Make Your Own Square Boring Bars

Square Bars for use with Torque Arresting Tool Rest.

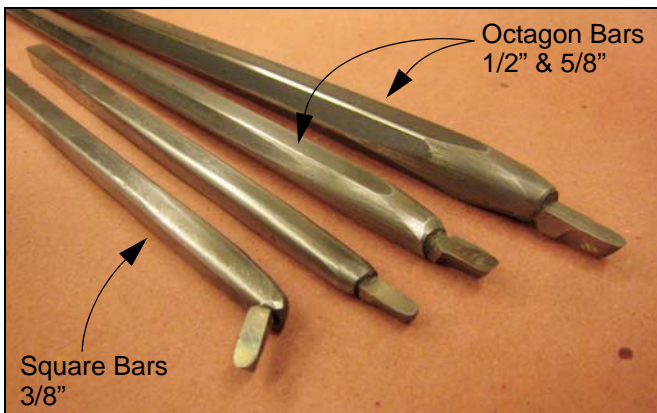

If you want to make your own square boring bars here is what you need:

<p>2 of 1/2" thick x 1/2" wide x 9" long steel bars, for straight and 45 degree boring bars <i>Note: 1/2" bars rather than 3/8" to match Derry Torque Arresting Tool Rest</i> <i>A 5/8" Octagon bar fits in a smaller hole than a 5/8" square bar!</i></p>	<p>For 1/2" bars use 1 of www.mcmaster.com #6552K193, 4140 Alloy Steel Square Bar 1/2" x 36" <i>Note: 1/2" O1 square tool steel costs 3 times more than 1/2" O1 drill rod. 4140/4142 Alloy Steel is a cheaper alternative.</i> Or for 3/8" bars use 1 of www.mcmaster.com #6552K193, 4140 Alloy Steel Square Bar 3/8" x 36" (\$13) Or for 5/8" bars use 1 of www.mcmaster.com #6552K193, 4140 Alloy Steel Hexagonal Bar 5/8" x 36" (\$31)</p>	<p>\$14</p>
<p>2 of 3/16" square tool bits</p>	<p>1 of www.msdirect.com #02605129 (\$3) M2 HSS with 10% cobalt Or 1 of www.mcmaster.com #3363A8 (\$8) M42 Cobalt or Better Yet get a perfectly ground bit by an expert (David Ellsworth) from www.packardwoodworks.com # 106215 (\$8)</p>	<p>\$6</p>

Eraser

Chalk

Making Your Own Boring Bars in a Nutshell:

1. After cutting the square bars to length round over the square edges with a belt sander, otherwise they act like scrapers!
2. Bore 3/16" holes in the ends for tool bits.
3. Cut a 2.5" long tool bit in half by scoring it with a grinder. Then hold it in a vise and hit it with a hammer. It will snap in half. See "Grind Your Own Tips Step by Step" photo above.
4. Drill a hole in the end of a 1/2" wooden dowel and use it to hold the tool bits while you grind one end round to fit hole in bars. *Note: Above photo shows a steel bar. Wooden dowel is easier.*
5. Grind Ellsworth style cutting tip on the other end. Compare yours to one you purchased.
6. Use thick super glue to hold the bits in the holes. *Note: The tool bits can be removed at a latter date by heating them with a torch.*

Make Your Own Torque Arresting Tool Rest

You will need a drill press, grinder, drills, taps, and basic metal working experience.

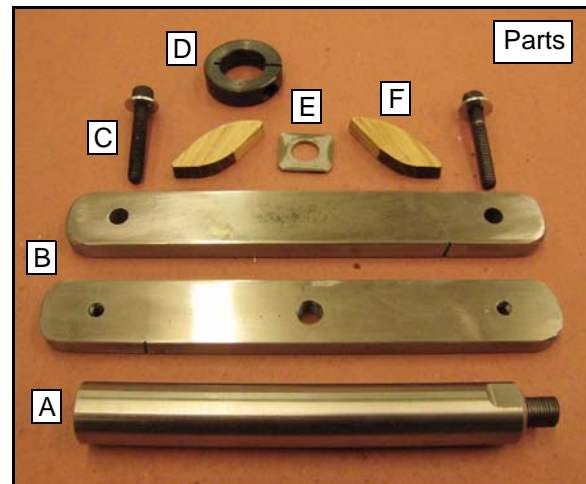

If you want to make your own Torque Arresting Tool Rest here is what you need:

A. 1 of Tool Post with Threads on Top (The right size for your lathe)	1 of www.woodcraft.com #123583, 1" x 5", \$15 or 1 of www.woodturnerscatalog.com #361-5006, 1" x 8", \$31
B. 2 of 1/2" thick x 1 1/4" wide x 9" long steel bar. Any old steel is good enough	Local Steel Supplier (see Yellow Pages) or 1 of www.mcmaster.com #8910K935, 1018 Low Carbon Steel, 0.5" x 1.25" x 36", \$22
C. 2 of 5/16"-18 TPI x 2" Bolts or Cap Screws with Washers	Local Hardware Store Or www.mcmaster.com # 91251A591, Socket head cap screw, 5/16"-18 Thread, 2" Length, 25 per package, \$7
D. 1" Shaft Collar (optional)	1 of www.mcmaster.com # 6435K18, \$4
E. 1/2" Round Washer (grind to a square)	Local Hardware Store
F. 2 Wood Spacers. Thickness of your square boring bars + 1/16"	Scrap Box

Chalk

Eraser

Directions:

1. Cut steel bars to length. You need 2 of them 9" long. The bottom one must be at least 1/2" thick so it will be sturdy when threaded onto tool post.
2. Check the thread on your tool post. **Beware!** The Woodcraft tool posts are 1/2" by 13 TPI thread (**course thread**), 27/64" drill. The tool posts from Craft Supplies USA are 1/2" by 20 TPI thread (**fine thread**), 29/64 drill.
3. Drill and tap hole in bottom of center bar for tool post. See #2 for correct size. Drilling and tapping is easier if you use cutting oil. I like "Tap Magic" in spray can.
4. Clamp the 2 steel bars together and drill a 17/64" hole all the way thru both bars 1" in from end of bars. *Note: Drilling thru 1" of steel is easier with a good short machiest drill bit like [#28765A36](http://www.mcmaster.com)*
5. Tap the holes in the bottom bar ONLY (the bar with post hole) with a 5/16" by 18 TPI tap.
6. Enlarge the holes in the top bar ONLY with a 3/8" drill bit. The bolts should fit loosely in these holes.
7. Temporarily bolt the 2 bars together with short bolts and round over the ends for safety. A 36 grit belt sander is faster than a grinder. Belt sand the rest of the bars to clean them up and make pretty.
8. Cut 2 wood spacers. 1/2" wide, 2 long. Height should be 1/32" of an inch bigger than the square or octagon boring bars you want to use.
9. Assemble the rest. The Craft Supplies USA tool post needs a 1/2" washer under the bottom bar to get a tight fit. Super glue or braze the post to bottom bar for safety. Carefully! File off the top of the post to be flush with top of bottom bar.



Morris Taper Shank Drills



I like to drill a depth hole in center of hollow form before hollowing. The hole makes it a lot easier to hollow. No nib to deal with.

I like to use Morris Taper Shank drills that mount directly into the tail stock of lathe without a Jacobs chuck. The drills I like have a raised edge on each flute that minimizes binding in deep holes. Always use short drill to start hole. Switch to smaller diameter long drill if needed. Taper shank drills at reasonable prices are available from MSC Direct at www.mscdirect.com.

Short Drill. 21/32" (just over 5/8") x 5-1/8" flute (9-3/4" overall length)	www.mscdirect.com , 2MT is item #01520428, 3MT is item #01530427	\$15
Long Drill. 5/8" x 10" flute (15" overall)	www.mscdirect.com , 2MT only item #01663400	\$58
2MT to 3MT Adapter (sleeve)	www.mscdirect.com , item #00070235	\$8

Bench Grinder Wheel

Bench Grinder Wheel (My favorit wheel)	www.mscdirect.com #75941443 (\$34) Norton, Gemini, Fine 100/120, 8" x 1" x 1", Gray, Aluminum Oxide	\$34
--	--	------

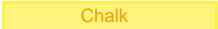
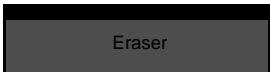

Demo Outline

1. Introduction
 - 1.1. Show examples of vases and rattles
 - 1.1.1. Great way to experiment with forms
 - 1.1.2. Great way to experiment with surface decorations
 - 1.2. Show small versus large Ellsworth style tools
 - 1.2.1. Small tools are low stress
 - 1.3. Talk about what makes a form easy or hard to hollow
 - 1.4. Talk about wood selection
2. Turn Small Vase
 - 2.1. Mount between centers. Cut tenon for chuck. Mount in chuck
 - 2.2. Shape the outside in forward. Talk about good shape
 - 2.3. Drill depth hole. Talk about why we drill. To avoid nib problem
 - 2.4. Show procedure for hollowing on white board
 - 2.5. Hollow with straight tool in reverse
 - 2.5.1. Mount laser. Better for demo. Talk about feeler wires if no laser
3. Switch to bent tool
4. Switch to square boring bars with torque arresting tool rest



Chalk

Eraser

Class Outline (2 Days)

Day 1

1. Morning:
 - 1.1. Introduction
 - 1.1.1. Safety
 - 1.1.2. Lathes
 - 1.2. Demo: Round Boring Bars. See "Demo Outline" on page 8, items 1 to 3.
 - 1.3. Students turn "Easy Tulip Vase". See "Easy verses Hard Hollow Forms: (Rules of Thumb)" on page 2
2. Lunch
3. Afternoon:
 - 3.1. Demo: Painting on the Lathe. See my "Painting on the Lathe for Dummies" handout.
 - 3.1.1. Introduction to Golden acrylic paints
 - 3.1.2. Designing with paints and color schemes
 - 3.1.3. Mixing paints
 - 3.1.4. Applying paints with brush with lathe running
 - 3.1.5. Introduction to Sharpie magic markers.
 - 3.2. Students finish 1st vase. Start on 2nd vase.

Day 2

1. Morning:
 - 1.1. Demo: Square Boring Bars with Torque Arresting tool rest.
 - 1.2. Students finish 2nd vase. Start on 3rd vase.
2. Lunch
3. Afternoon:
 - 3.1. Demo: Introduction to Woodburst Stains. See my "Painting on the Lathe for Dummies" handout.
 - 3.2. Students finish 3rd vase.
 - 3.3. Clean up



Eraser



Chalk