

BEWARE! Your printer may not print this page correctly. Double check the 7 inch dimension and make any necessary adjustments. Change "Page Scaling" to "none" on Print Menu, etc.

Ellsworth Gouge with Ellsworth Jig & Arm

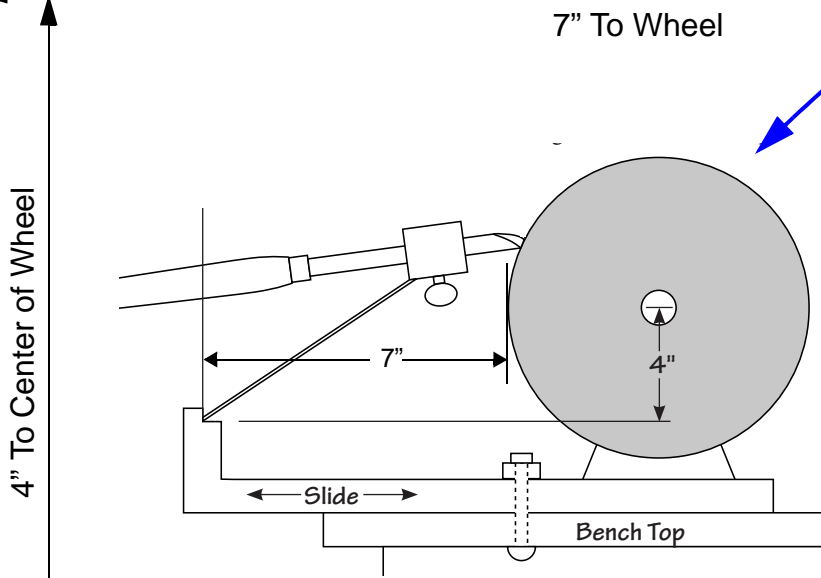
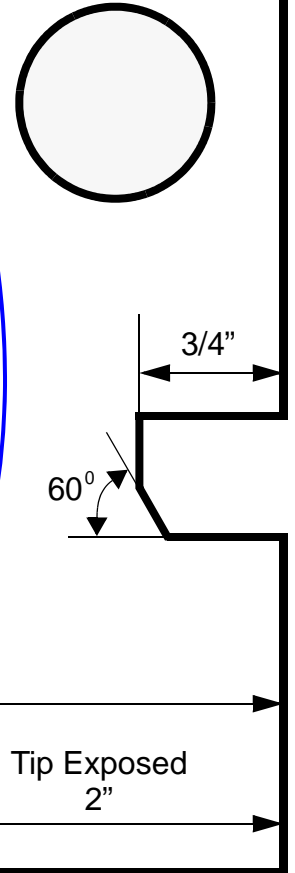
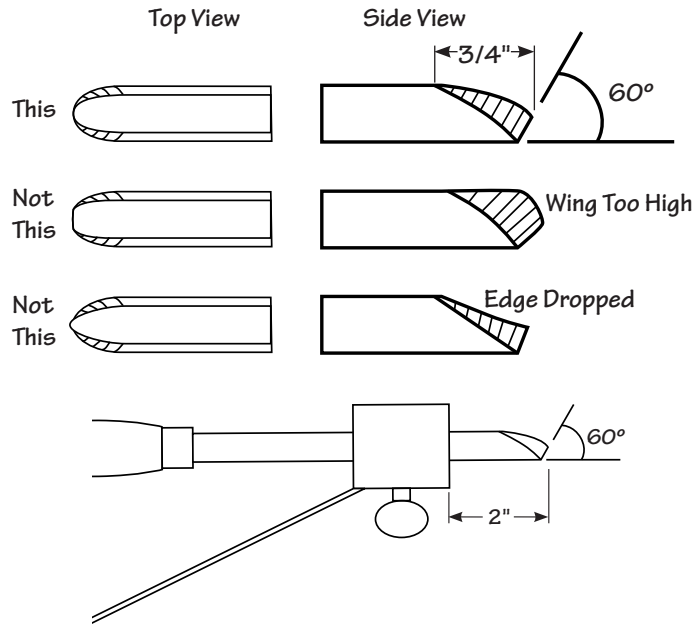

Spray glue this template to a 1/4" piece of plywood. Then cut it out to create a template for setting up grinder.

www.carlford.info

Eraser

Chalk

BEWARE! Your printer may not print this page correctly. Double check the 7 inch dimension and make any necessary adjustments. Change "Page Scaling" to "none" on Print Menu, etc.

Ellsworth Gouge with Ellsworth Jig, Wolverine Arm

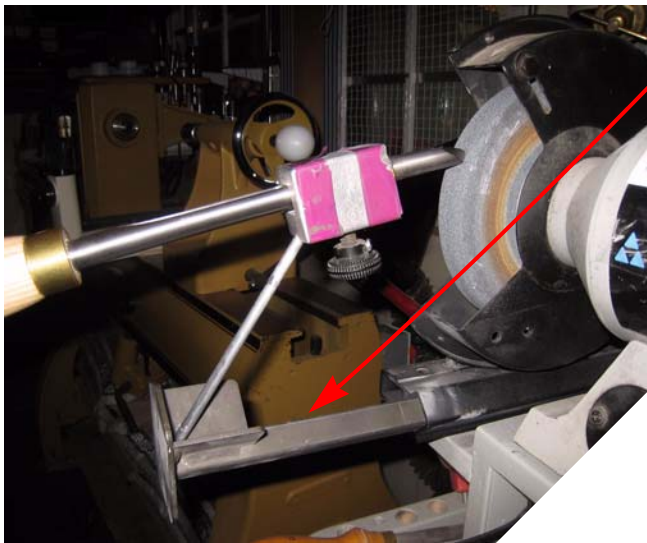
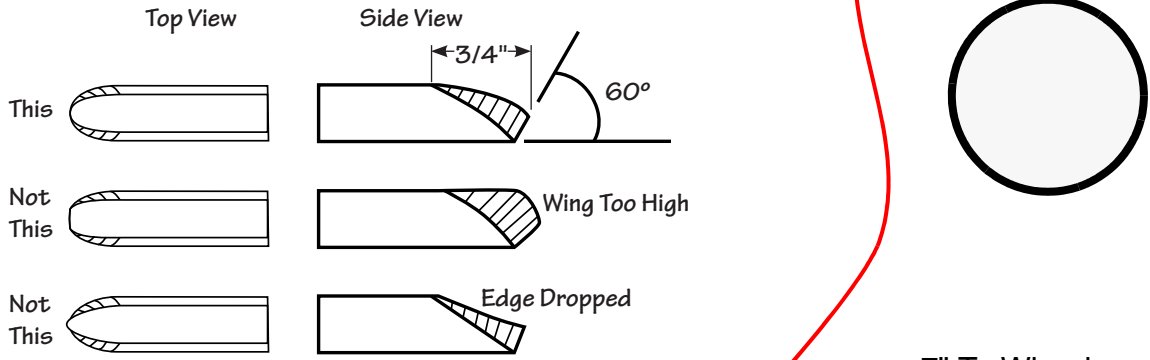

5 1/4" To Center of Wheel

Tip Exposed
2 1/8"

Spray glue this template to a 1/4" piece of plywood. Then cut it out to create a template for setting up grinder.

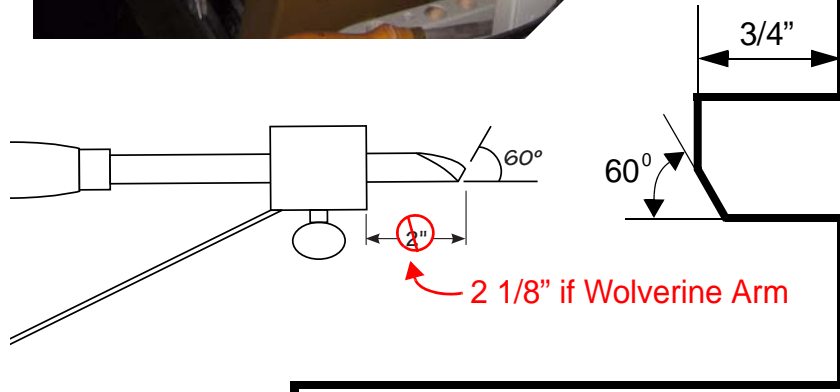

www.carlford.info

www.carlford.info

Chalk

Eraser

BEWARE! Your printer may not print this page correctly. Double check the 6 1/2 inch dimension and make any necessary adjustments. Change "Page Scaling" to "none" on Print Menu, etc.

Ellsworth Gouge with Wolverine Varigrind Jig

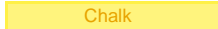
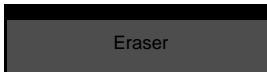
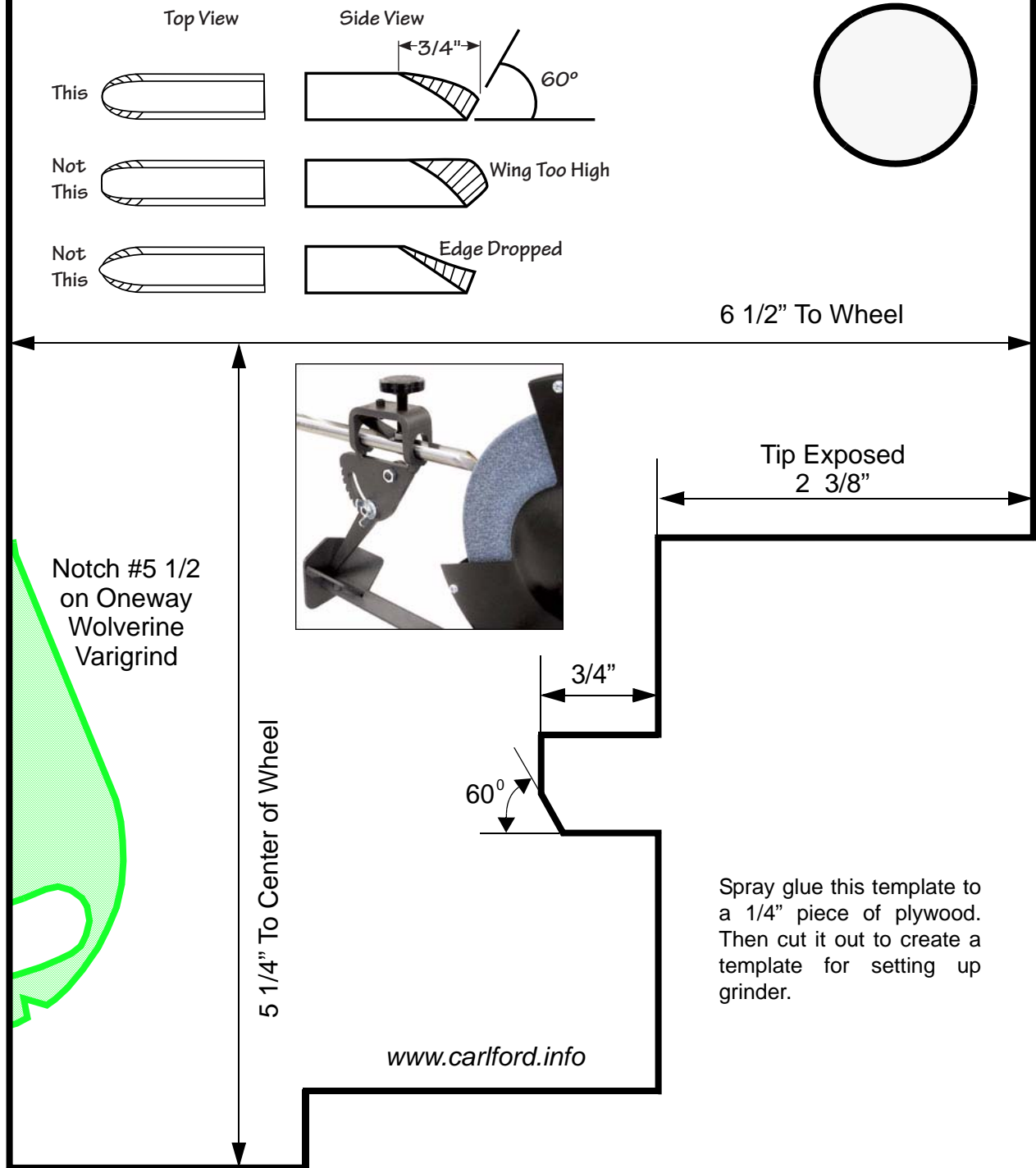

BEWARE! Your printer may not print this page correctly. Double check the 6 inch dimension and make any necessary adjustments. Change "Page Scaling" to "none" on Print Menu, etc.

12mm (1/2") Detail Gouge with Hosaluk Grind

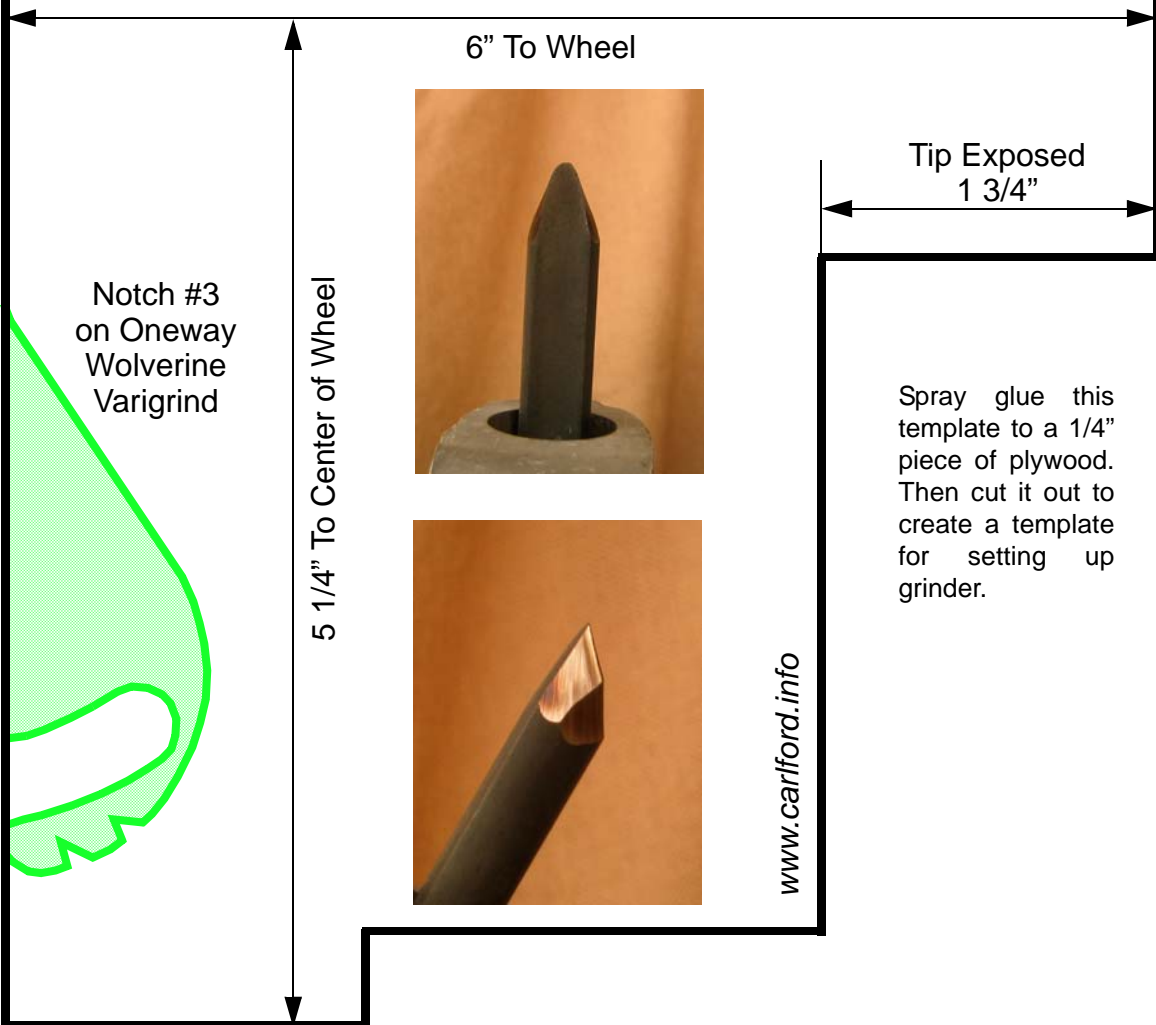
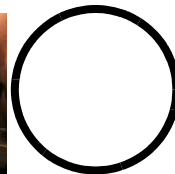

www.carlford.info

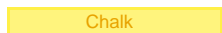

BEWARE! Your printer may not print this page correctly. Double check the 6 inch dimension and make any necessary adjustments. Change "Page Scaling" to "none" on Print Menu, etc.

16mm (5/8") Detail Gouge with Hosaluk Grind



5 1/2" To Wheel

Tip Exposed
1 3/4"

Notch #3
on Oneway
Wolverine
Varigrind

5 1/4" To Center of Wheel



Spray glue this
template to a 1/4"
piece of plywood.
Then cut it out to
create a template
for setting up
grinder.

www.carlford.info

www.carlford.info

Eraser

Chalk